

N20010, N34010 NON-SPRING RETURN DAMPER ACTUATOR 20/34 Nm (177/300 lb-in) FOR MODULATING CONTROL

PRODUCT DATA

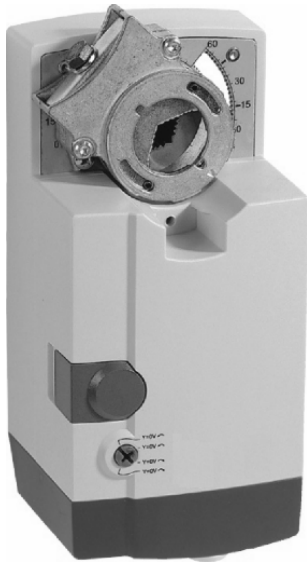

GENERAL

These direct-coupled damper actuators provide modulating control for:

- air dampers,
- VAV units,
- air handling units,
- ventilation flaps,
- louvers, and
- reliable control for air damper applications with up to 4.6 m² / 50 sq.ft. (20 Nm / 177 lb-in) or 7.8 m² / 85 sq. ft. (34 Nm / 300 lb-in) (seal-less dampers; air friction-dependent).

FEATURES

- **New self-centering shaft adapter**
- **Access cover to facilitate connectivity**
- **Declutch for manual adjustment**
- **Mechanical end limits**
- **Field-installable auxiliary switches**
- **Rotation direction selectable by switch**
- **Mountable in any orientation (no IP54 if upside down)**
- **Mechanical position indicator**

SPECIFICATIONS

Supply voltage	24 Vac \pm 20%, 50/60 Hz; 24 Vdc -10...+20%
Nominal voltage	24 Vac, 50/60 Hz; 24 Vdc
<i>All values stated hereinafter apply to operation under nominal voltage conditions.</i>	
Power consumption	
N20010	6 VA / 6 W
N34010	8 VA / 6 W
Ambient limits	
Ambient operating limits	-20...+60 °C (-5...+140 °F)
Ambient storage limits	-40...+80 °C (-40...+175 °F)
Relative humidity	5...95%, non-condensing
Safety	
Protection standard	IP54
Protection class	II as per EN 60730-1
Overvoltage category	II
Lifetime	
Full strokes	60000
Repositions	1.5 million
Mounting	
Round damper shaft	10...27 mm (3/8...1-1/16")
Square damper shaft	10...18 mm (3/8...11/16"); 45° steps
Shaft length	min. 22 mm (7/8")
Control signal	
	0(2)...10 Vdc 0(4)...20 mA
Input impedance	100 k Ω [0...10 V] 500 Ω m [0...20 mA]
Feedback signal	
Limits	\pm 1 mA at 0...10 V
End switches (when included)	
Rating	5 A (resistive) / 3 A (inductive)
Triggering points	5° / 85°
Torque rating	
N20010	20 Nm (177 lb-in)
N34010	34 Nm (300 lb-in)
Runtime	95 sec (60 Hz) / 110 sec (50 Hz)
Rotation stroke	95° \pm 3°
Dimensions	see "Dimensions" on page 8
Weight (without cables)	1.35 kg (3 lbs.)
Noise rating	45 dB(A) max. at 1 m
Software	Class A as per EN 60730-1

MODELS

order number	supply voltage	end switches	control signal	feedback	torque
N20010	24 Vac	--	0...10 Vdc / 0...20 mA	0...10 Vdc	20 Nm (177 lb-in)
N20010-SW2	24 Vac	2	0...10 Vdc / 0...20 mA	0...10 Vdc	20 Nm (177 lb-in)
N34010	24 Vac	--	0...10 Vdc / 0...20 mA	0...10 Vdc	34 Nm (300 lb-in)

Product Identification System

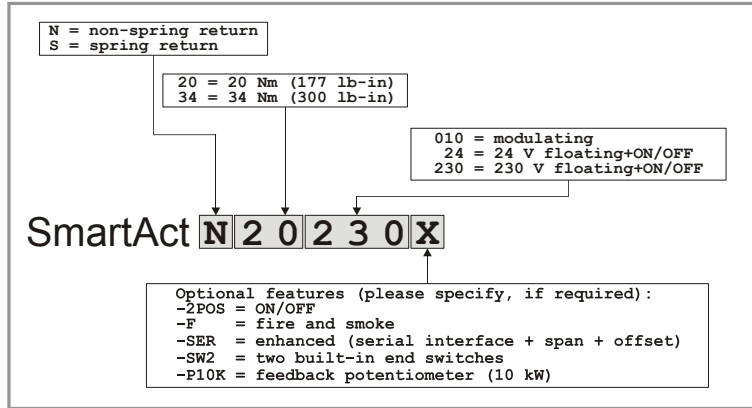

Fig. 1. Product Identification System

OPERATION / FUNCTIONS

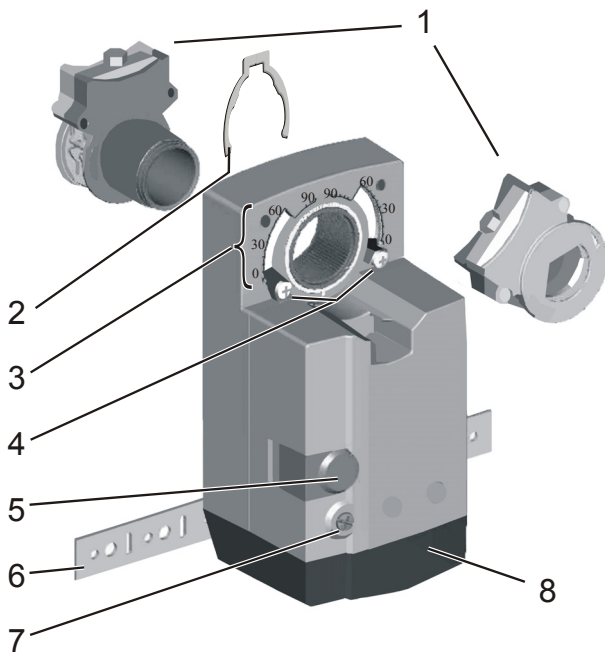

Fig. 2. Setting units and control elements

Legend for Fig. 2:

- 1 Self-centering shaft adapter
- 2 Retainer clip
- 3 Rotational angle scales (0...90° / 90...0°)
- 4 Mechanical end limits (20 Nm [177 lb-in] models, only)
- 5 Declutch button
- 6 Anti-rotation bracket
- 7 Rotation direction switch
- 8 Access cover

Contents of Package

The delivery package includes the actuator itself, parts 1 through 8 (see Fig. 2), the anti-rotation bracket screws, and the SM mounting plate and screws.

Modulating Control

The actuator is capable of being operated by several controllers providing Vdc or mA output.

Rotary Movement

The control signal and the corresponding rotation direction (clockwise or counterclockwise) can be selected using the rotation direction switch (see part 7 in Fig. 2), thus eliminating the need to re-wire. To ensure tight closing of the dampers, the actuator has a total rotation stroke of 95°.

As soon as operating power is applied, the actuator may start to run. When power is removed, the actuator remains in position. For actuator-controller wiring instructions, see section "Wiring" on page 5.

Rotation Direction Switch

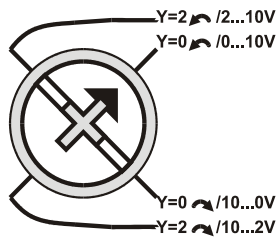

Fig. 3. Rotation Direction Switch

Table 1. Feedback/control signal values

rotation direction switch position	feedback/control signal when actuator is	
	totally ↻	totally ↻
Y=2 ↻ /2...10V	U = 2 V	U = 10 V
Y=0 ↻ /0...10V*	U = 0 V	U = 10 V
Y=0 ↻ /10...0V	U = 10 V	U = 0 V
Y=2 ↻ /10...2V	U = 10 V	U = 2 V

* Default shipping position.

Feedback Signal and Manual Adjustment

If, while the actuator is not rotating, the user declutches it and manually repositions the shaft adapter, the feedback signal will then follow the new position at which the shaft adapter has been left.

Power OFF/ON Behavior

In case the power to the actuator fails, after re-applying power, the actuator acknowledges its present position and follows the signal from the controller. This makes it unnecessary for the actuator to employ autoadaptation in order to re-map the control signal settings.

Dip Switches

The actuators are equipped with two dip switches accessible after removing the access cover (see Fig. 4).

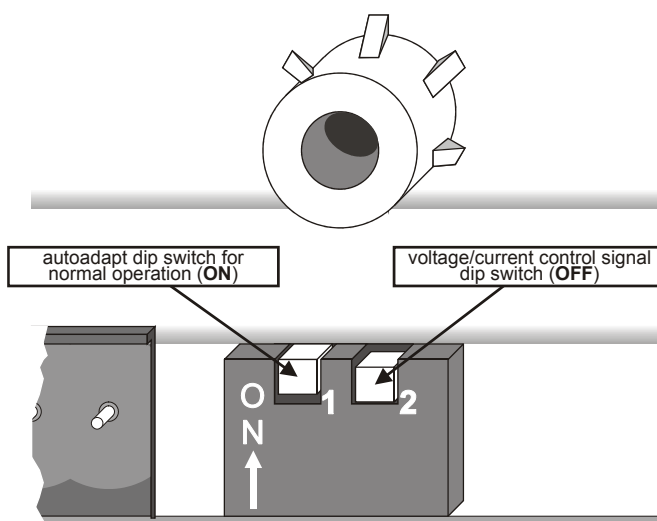

Fig. 4. Dip switches (view with PCB at bottom)

Autoadapt Dip Switch for Normal Operation

In its default shipping position, the autoadapt dip switch for normal operation is set to **ON** as shown in Fig. 4. If it is set to **OFF**, no autoadapting is performed, and the control signal map remains constant.

The autoadapt functionality does not have to be triggered. Rather, the SmartAct actuator does this automatically when the min. and max. control signals are provided (see Fig. 5); the feedback signal is likewise autoadapted.

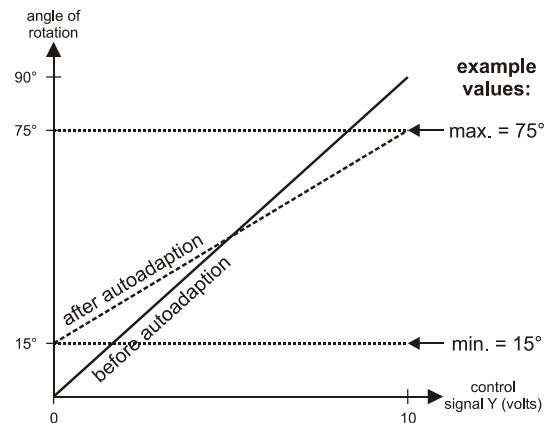

Fig. 5. Actuator positioning curve

Adjusting the Actuator for Autoadapt

In order to make use of the autoadapt functionality, proceed as follows:

1. Set the autoadapt dip switch to the ON position.
2. If necessary, limit the stroke to the desired range using the mechanical end limits.
3. Drive the actuator to the left end limit (totally counter-clockwise) by setting the control signal as specified in Table 1.
4. Drive the actuator to the right end limit (totally clockwise) by setting the control signal as specified in Table 1. The stroke has now been limited to 0...100% of the control signal range.

Voltage/Current Control Signal Selection Dip Switch

In its default shipping position, the voltage/current control signal dip switch (see Fig. 4) is set to **OFF** (= voltage control), as shown in Fig. 4. Setting it to **ON** results in current control.

Position Indication

The hub adapter indicates the rotation angle position by means of the rotational angle scales (0...90° / 90...0°).

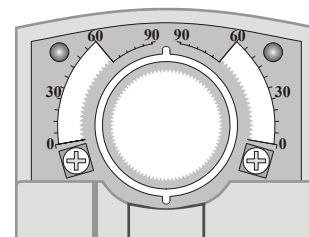

Fig. 6. Position indication

Manual Adjustment

IMPORTANT

In order to prevent equipment damage, you must remove power before manual adjustment.

After removing power, the gear train can be disengaged using the declutch button, permitting the actuator shaft to be manually rotated to any position. The feedback signal will then follow the new position.

Limitation of Rotation Stroke

Two mechanical end limits (adjustable in 3° increments) are provided (20 Nm [177 lb-in] models, only) to limit the angle of rotation as desired (see Fig. 7).

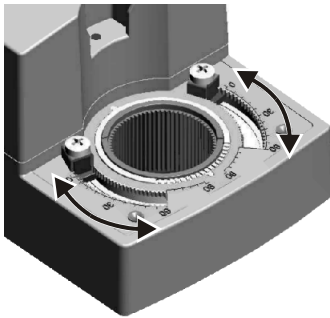

Fig. 7. Mechanical end limits

The mechanical end limits must be securely fastened in place as shown in Fig. 8. Specifically, it is important that they properly mesh with the rotational angle scales when the screws are tightened.

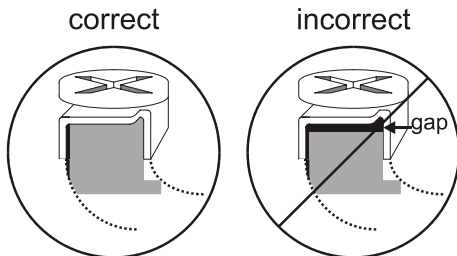

Fig. 8. Correct / incorrect tightening of end limits

Internal End Switches

NOTE: Only those actuators for which the option "-SW2" has been specified when ordering (e.g.: "N20010-SW2") feature internal end switches.

The internal end switches are set to change from "common" to "normally open" at angles of 5° and 85°, respectively, from the totally counterclockwise position.

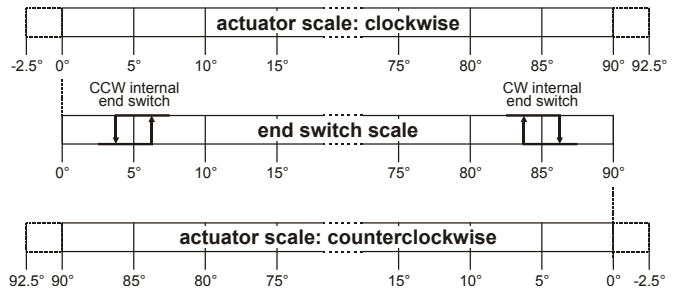

Fig. 9. Internal end switches

Override

If terminal Y of the terminal strip (see section "Wiring Diagrams" on page 6) is unplugged, the stroke will be 0%; reversing the rotation direction using the rotation direction switch will result in a max. stroke of 100%. If terminal Y is jumped with terminal 1 (24 Vac), the stroke will be 50%.

INSTALLATION

These actuators are designed for single-point mounting.

IMPORTANT

In order to prevent equipment damage, you must remove power or set the rotation direction switch to the "Service/Off" position before manual operation.

Mounting Instructions

All information and steps are included in the Installation Instructions supplied with the actuator.

Mounting Position

The actuators can be mounted in any desired orientation (no IP54 if mounted upside down; see Fig. 10). Choose an orientation permitting easy access to the actuator's cables and controls.

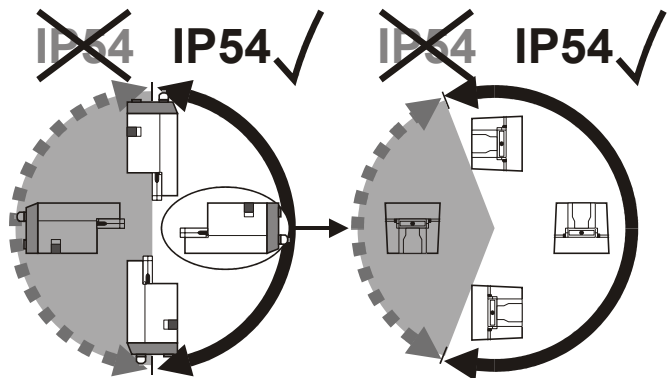

Fig. 10. Mounting for IP54

Mounting Bracket and Screws

If the actuator is to be mounted directly on a damper shaft, use the mounting bracket and screws included in the delivery package.

Self-Centering Shaft Adapter

The self-centering shaft adapter can be used for shafts having various diameters (10...27 mm [3/8...1-1/16"]) and shapes (square or round).

In the case of short shafts, the shaft adapter may be reversed and mounted on the duct side.

Stroke Limitation with Mechanical End Limits

The mechanical end limits (20 Nm [177 lb-in] models, only) enable the stroke to be limited from 0...90° in increments of 3°.

Wiring

Connecting to the Power Supply

In order to comply with protection class II, the power source of 24 V actuators must be reliably separated from the network power supply circuits as per DIN VDE 0106, part 101.

Access cover

To facilitate wiring the actuator to the controller, the access cover can be detached from the actuator.

IMPORTANT

Remove power before detaching the access cover. Once the access cover has been removed, please take care to avoid damaging any of the parts now accessible.

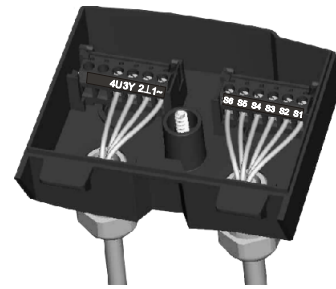

Fig. 11. Access cover (N20010-SW2)

Depending upon the model, the access cover may have one or two terminal strips, including a layout with a description for each of the terminals.

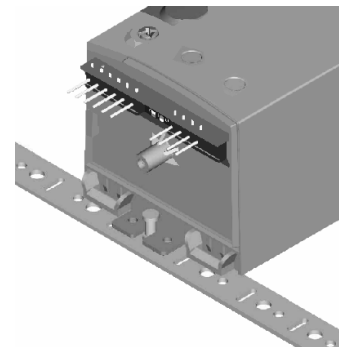
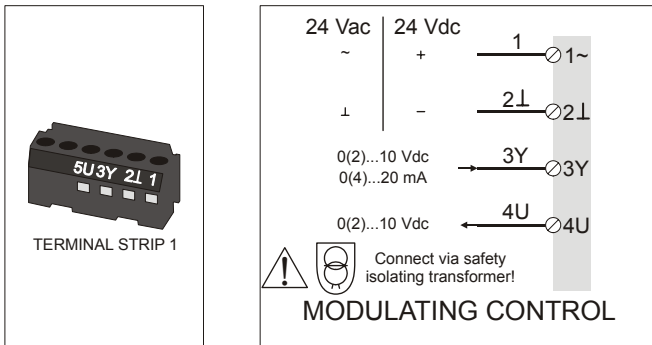

Fig. 12. N20010-SW2 with access cover removed

Wiring Diagrams

N20010 / N34010



N20010-SW2

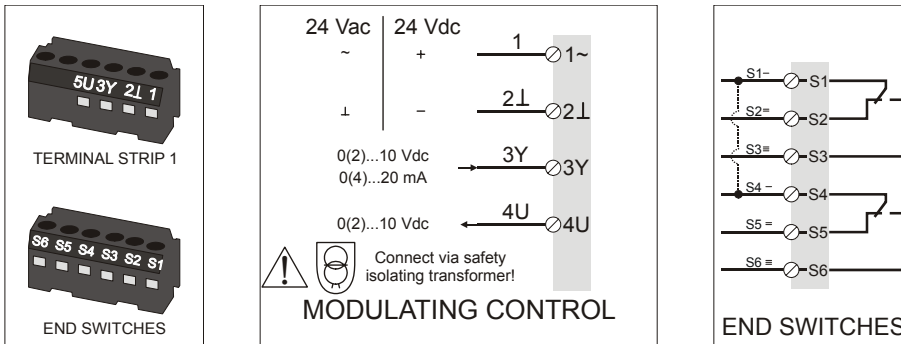

NOTE: Internal end switches S1 and S4 must be connected to the same power source.

connecting cable	terminal	name	
supply and signal lines (must be equipped with spark suppressors)	1~	24 Vac ~ / 24 Vdc +	
	2⊥	24 Vac ~ / 24 Vdc -	
	3Y	0(2)...10 Vdc / 0(4)...20 mA control signal	
	4U	0(2)...10 V feedback signal	
end switches (when included)	CCW (left) 5°	S1	common
		S2	normally closed
		S3	normally open
	CW (right) 85°	S4	common
		S5	normally closed
		S6	normally open

OPTIONAL ACCESSORIES

The following optional accessories can be ordered separately.

Auxiliary Switch Kit

Order no.: SW2

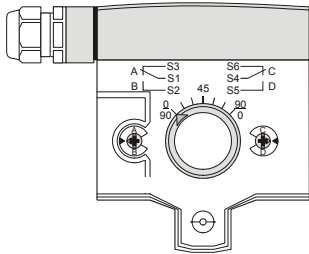

The internal auxiliary switches are field-installable parts providing two SPDT freely-adjustable switches.

Access Cover Kit

Order no.: WB20
For M20 outlets.

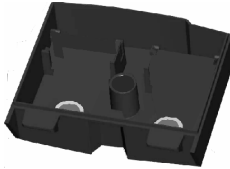

Contains:

- 1 access cover (with screw)
- 2 cable connectors
- 2 dust-protection caps

SPARE PARTS

Spare Parts Kit

Order no.: A7209.2071

The spare parts kit contains the following items:

- Anti-rotation bracket and screws
- SM Mounting plate and screws
- Access cover screw
- Plastic protective cap for protection standard IP54
- Mechanical end limit screw and retainer

Anti-Rotation Bracket Kit

Order no.: A7209.2073

The anti-rotation bracket kit can be ordered separately.

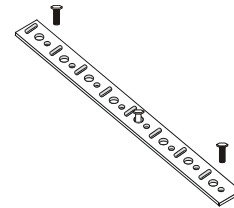

Contains:

- 10 anti-rotation brackets
- 20 screws

SM Mounting Plate Kit

Order no.: A7209.2072

The SM mounting plate kit can be ordered separately.

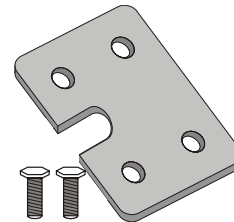

Contains:

- 10 SM mounting plates
- 20 screws

DIMENSIONS

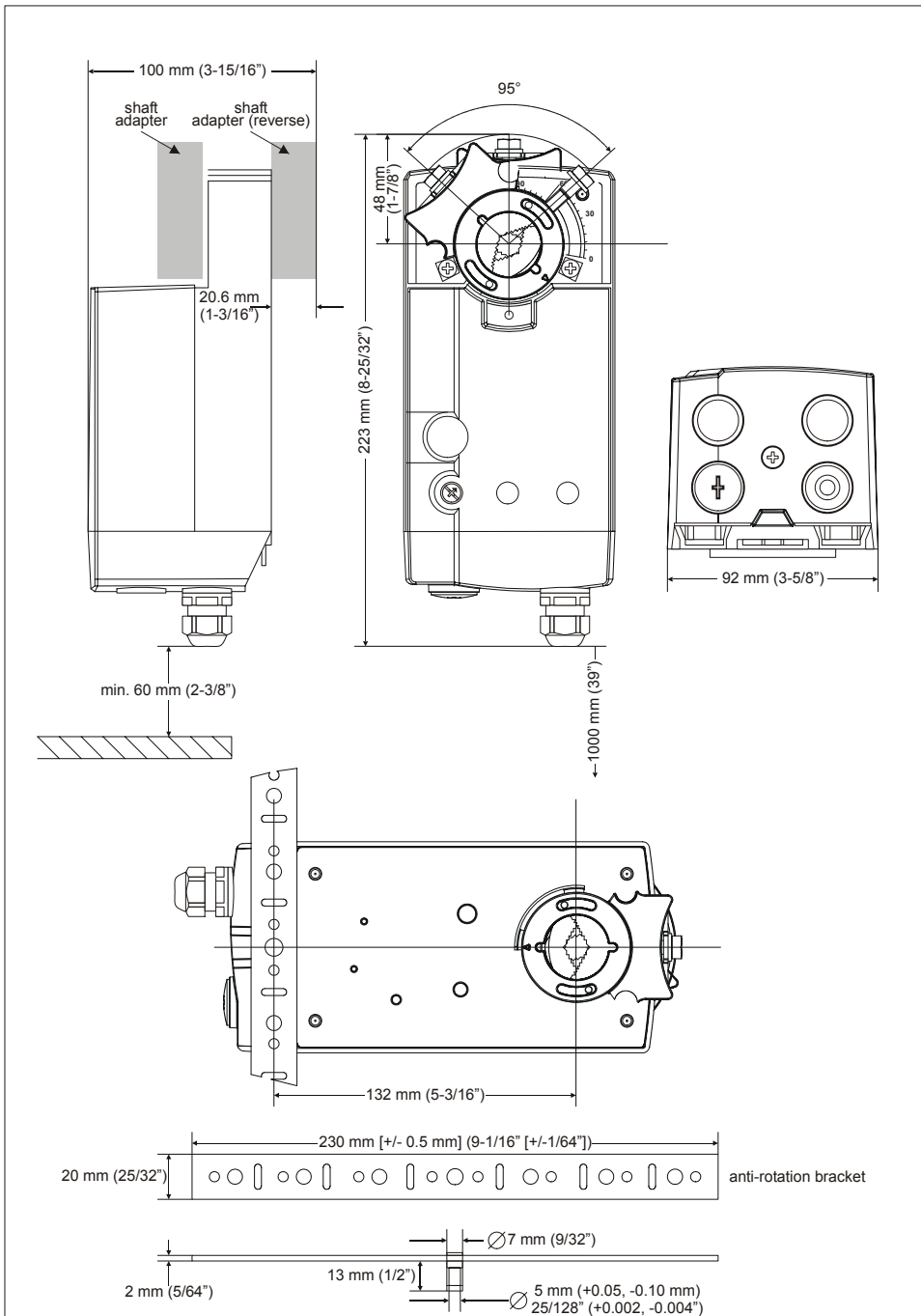

Honeywell

Manufactured for and on behalf of the Environmental and Combustion Controls Division of Honeywell Technologies Sàrl, Ecublens, Route du Bois 37, Switzerland by its Authorized Representative:

Automation and Control Solutions

Honeywell GmbH
 Böblinger Straße 17
 D-71101 Schönaich
 Phone: (49) 7031 63701
 Fax: (49) 7031 637493
<http://europe.hbc.honeywell.com>

Subject to change without notice. Printed in Germany

Manufacturing location certified to **DIN EN ISO 9001**

EN0B-0341GE51 R0307